



MT4000

TRAVELING WAVE TUBE MEDIUM POWER AMPLIFIER

FOR SATELLITE UPLINK APPLICATIONS

C-BAND: 750W
X-BAND: 750W
Ku-BAND: 750W
DBS-BAND: 500W
750W



AVAILABLE SYSTEM OPTIONS:

MT4011 1 + 1 Redundant System

MT4012 1 + 2 Redundant System

MT40PC Phase Combined, Single Path Redundant System

Other Configurations Available Upon Request

AVAILABLE AMPLIFIER OPTIONS:

Parallel Remote Interface

Manual Attenuator

Internal Linearizer

Extended Band Operations

Remote Panel

Block Upconverter (L-Band)

FEATURES:

Event Log Screen with Report of Amplifier Status, Level Date, and Time

Auto Power Control and Status

Continuous Attenuator Adjustment in dB

Filament Off State to Conserve Power and Extend Tube Life

Local, Remote, or Computer Control Modes

Front Panel RS232 Diagnostic Interface

Sample Port Coupling Factor Screen

ISO 9001



501 S. Woodcreek Drive, Bolingbrook, IL U.S.A., 60440-4999 • 630-759-9500 FAX: 630-759-5018

MT4000

TRAVELING WAVE TUBE MEDIUM POWER AMPLIFIER

ELECTRICAL SPECIFICATIONS	C-BAND	X-BAND	Ku-BAND	DBS-BAND
	750 W	750 W	750 W	500/750 W
Frequency Range (F ₀) (Standard): (Extended): (Extended): (Extended):	5.850 - 6.45 GHz Option: 5.850 - 6.725 GHz Option: 5.850 - 6.75 GHz Option: 5.850 - 7.10 GHz	7.9 - 8.4 GHz	13.75 - 14.5 GHz Option: 12.75 - 14.5 GHz Option: 14.56 - 15.35 GHz	17.3 - 18.4 GHz
Output Power (min.): Tube Output Flange: HPA Rated Output:	750 W (58.75 dBm) 665 W (58.25 dBm)	750 W (58.75 dBm) 665 W (58.25 dBm)	750 W (58.75 dBm) 665 W (58.25 dBm)	500/750 W (57/58.75 dBm) 420/630 W (56.2/58.0 dBm)
Gain: At Rated Power (min.): Small Signal Gain (SSG) (min.): Attenuation Range: Maximum SSG Variation Over: Narrow Band: Per 500 MHz: Slope, Max.: Gain Stability: Stability, Any Freq. Over Entire Temp.: Stability, Any Freq. ±10°C:	72 dB 77 dB 30 dB (0.10 Step) .5 dB/40 MHz 2.5 dB ±0.04 dB/MHz ±1.0 dB typ. ±0.75 dB max.	71 dB 76 dB 30 dB (0.10 Step) 1.0 dB/80 MHz 2.5 dB ±0.04 dB/MHz ±1.0 dB typ. ±0.75 dB max.	72 dB 77 dB 30 dB (0.10 Step) 1.0 dB/80 MHz 2.5 dB ±0.04 dB/MHz ±1.0 dB typ. ±0.75 dB max.	65 dB 71 dB 30 dB (0.10 Step) 1.0 dB/80 MHz 4.0 dB ±0.04 dB/MHz ±1.0 dB typ. ±0.75 dB max.
Input VSWR:	1.20:1 max. with respect to 50 ohms			1.25:1 max. with respect to 50 ohms
Output VSWR:	1.25:1 max.			1.30:1 max.
Load VSWR:	2.0:1 max. without damage, continuous			2.0:1 max. without damage, continuous
AM/PM Conversion: At Rated Power: 6 dB Below Rated Power:	6.0°/dB max. 2.5°/dB max.	6.0°/dB max. 2.5°/dB max.	6.0°/dB max. 2.5°/dB max.	8.0°/dB max. 3.0°/dB max.
Residual AM Noise, Max.: To 10 kHz: 10 - 500 kHz: Above 500 kHz:	-50 dBc -20 [1.5 + Log _f (kHz)] dBc -85 dBc			
Harmonic Output, Max.:	-60 dBc			
Noise & Spurious, Max.: Receive Band (Standard): (Extended): Transmit Band (F ₀):	-150 dBW/4 kHz, 3.4 - 4.2 GHz -150 dBW/4 kHz, 3.4 - 4.2 GHz -70 dBW/4 kHz	-70 dBW/4 kHz, 7.25 - 7.75 GHz N/A -70 dBW/4 kHz	-150 dBW/4 kHz, 10.7 - 12.75 GHz -150 dBW/4 kHz, 10.7 - 11.70 GHz -70 dBW/4 kHz	-150 dBW/4 kHz, 10.7 - 12.75 GHz N/A -65 dBW/4 kHz
Phase Noise, Max.: AC Fundamental: Sum Of All Except AC Fundamental:	10 dB below IESS Phase Noise Profile -50 dBc -47 dBc			
Intermodulation, Max.: (for 2 equal carriers relative to single carrier rated output): Linearizer Option:	Total P ₀ -4 dB -7 dB -4 dB	IM Product -18 dBc -24 dBc -27 dBc	Total P ₀ -4 dB -7 dB -4 dB	IM Product -18 dBc -24 dBc -27 dBc
Group Delay, Max.: Linear: Parabolic: Ripple:	Any 40 MHz Bandwidth 0.01 ns/MHz 0.005 ns/MHz ² 0.5 ns p-p	Any 40 MHz Bandwidth 0.01 ns/MHz 0.005 ns/MHz ² 0.5 ns p-p	Any 80 MHz Bandwidth 0.01 ns/MHz 0.005 ns/MHz ² 0.5 ns p-p	Any 80 MHz Bandwidth 0.01 ns/MHz 0.005 ns/MHz ² 0.5 ns p-p
Prime Power: Voltage: Power Consumption: Power Factor: In-Rush: Input Transients:	180 - 264 VAC, 1-phase, 2-Wire, 47 - 63 Hz 2.4 KVA typ. at Rated Power Out (See Note) 0.95 min. 28A max. EN61000-4-4,4-5,4-11 (Surge, Fast Transients, Line Dropout)			

Note* Input power will be greater if the HPA is driven to saturation.

700 W output power
70 W output power
No output power

2400 VA input power
1650 VA input power
1600 VA input power

Note: Performance information is subject to change without notification. Contact MCL for the latest specifications (TN4000-1).

RF BLOCK DIAGRAM

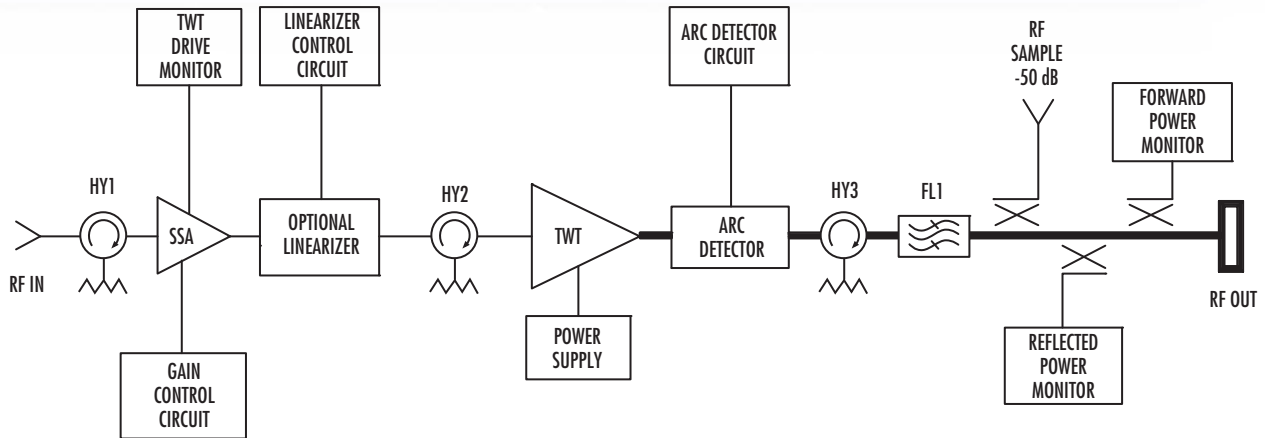

CONTROL AND STATUS CAPABILITIES

TYPE	FUNCTION		
Controls	Filament ON/OFF Transmit/Standby RF ON/OFF Reset Attenuation	Units Select Hold Power ON/OFF Auto Switching (1:1) Manual Switching (1:1)	Fault Counter ON/OFF Antenna Position (1:1) Load Position (1:1) Local/Remote/Computer
Adjustable Parameters	Auto Power Tube Temperature Alarm RF Low Alarm Comm Address Date	Tube Overdrive Alarm RF Reflected Power Alarm RF High Alarm Comm Baud Rate Time	Tube Overdrive Fault RF Reflected Power Fault Filament Under Current Fault Comm Protocol
Displays	RF Forward Power Helix Voltage Filament Delay	Tube Drive Helix Current Tube Temperature	RF Reflected Power Filament Current PS Temperature
Faults (Notification, RF & HV Shutdown)	Tube Temperature Switch Tube Temperature Analog Helix Run Current HV Under Voltage User Interlock	WG Pressure WG Arc Helix Surge Current HV Over Voltage	Arc Test Failed PS Temperature Chassis Interlock Filament Under Current
Alarms (Notification Only)	RF High RF Reflected Blower Failed Exciter	RF Low Tube Temperature AC Low Line	Tube Overdrive PS Temperature RF Switch Failed
Additional Status	Delay Summary Alarm Computer Tx Remote Rx Maintenance Log	Transmit Selected Summary Fault Computer Rx Event Log	Sampler Port Cal Table RF Low Switching ON/OFF Remote Tx Fault Log

MT4000

OUTLINE DRAWING

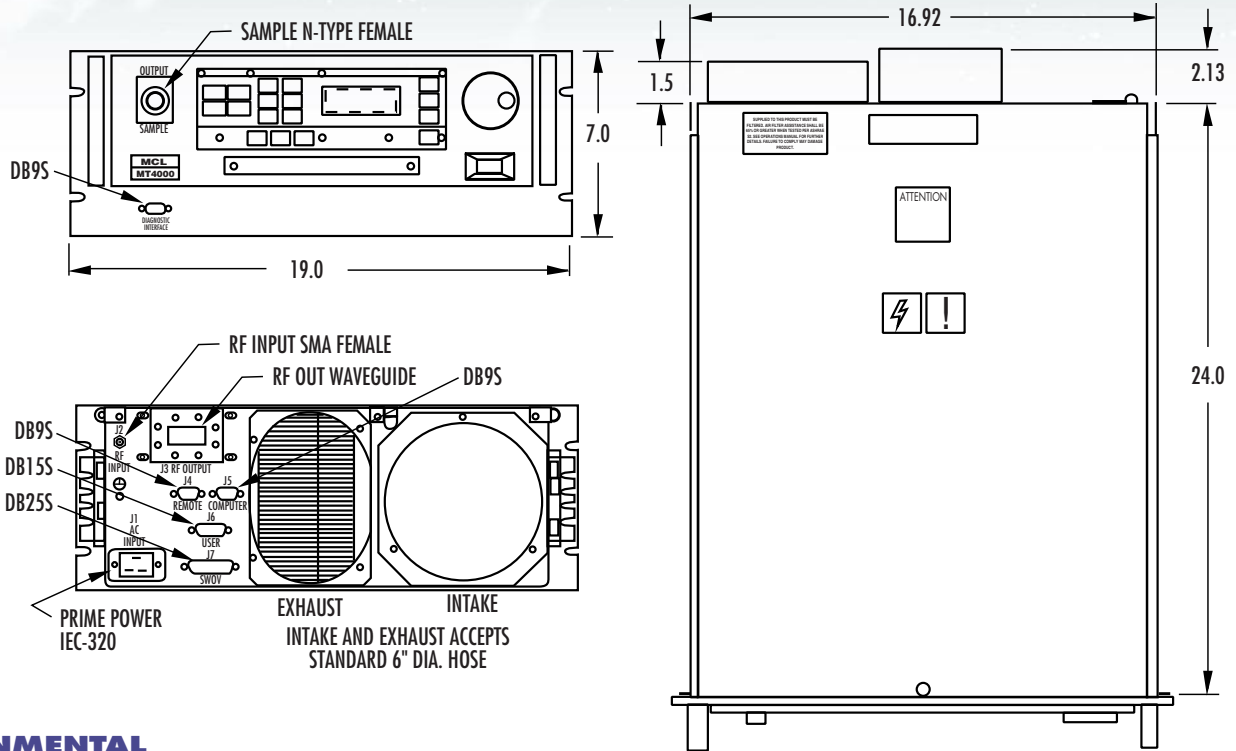

ENVIRONMENTAL SPECIFICATIONS

Operating Temperature:

0°C to +50°C (derated 1.9°C per 1,000 ft. above sea level)

Non-Operating Temperature:

-40°C to +70°C

Relative Humidity:

95%, non-condensing

Operating Altitude:

10,000 ft. above sea level (3,048 m)

Non-Operating Altitude:

50,000 ft. above sea level (15,240 m)

Vibration:

Basic Transport Method 514-4 of MIL-STD-810E Category I, Figures 514.4-1, 514.4-2, 514.4-3

Shock:

10 g, 11ms half sine pulse along each of 3 orthogonal axes

Maximum Backpressure:

.5 inches of water (exhaust air)

MECHANICAL SPECIFICATIONS

RF Connectors:

Input: Type SMA female (C, X, Ku, DBS)

Output: (Waveguide Flange)

C-Band: CPR137F

X-Band: WR112F

Ku-Band: WR75F

DBS-Band: WR62F

Installed Weight:

75 lbs. nominal/34 kg.

Cooling:

Closed Loop

Acoustic Noise:

68 dBA at 1 meter (from front panel)

PHYSICAL SPECIFICATIONS

Dimensions:

7.00" H (178.00 mm)

19.00" W (483.00 mm)

24.00" L (610.00 mm)

Air Flow:

190 CFM

MCL, INC
501 S. Woodcreek Drive, Bolingbrook, IL U.S.A., 60440-4999 • 630-759-9500 FAX: 630-759-5018
24-HOUR CUSTOMER SUPPORT NUMBER IN THE USA: 1-800-743-4625
OUTSIDE THE USA: 312-461-4536 • www.mcl.com



MT4000-11.09